

**B1=B2=B3=B5=B6=B7=B11=
B17=B18=B24=B25=B31=B32=
B33=B34=B35=B37=B41=B43=
B44=B45=B47=B48**

1xC30
PLANTA
ESC.: 1:25

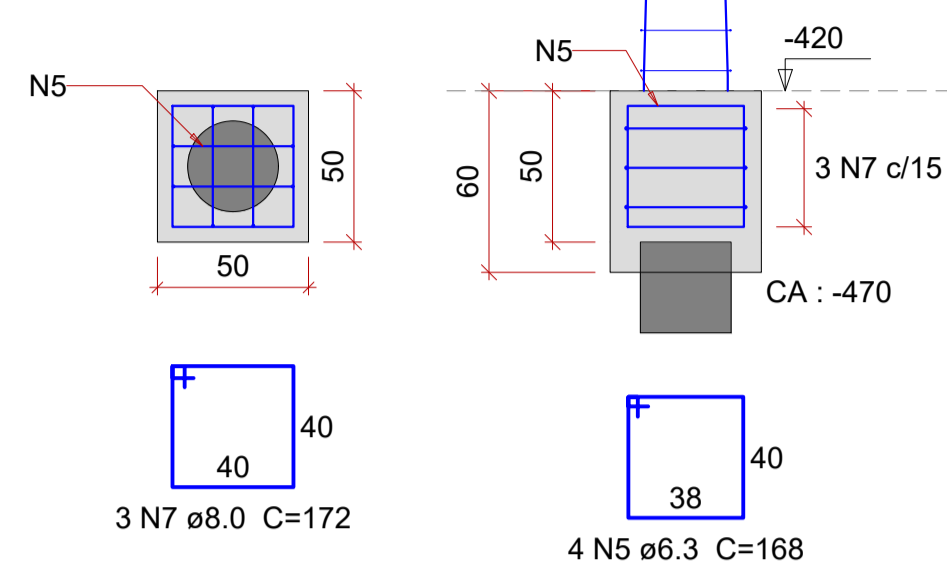

**P1=P2=P6=
=P44=P45**

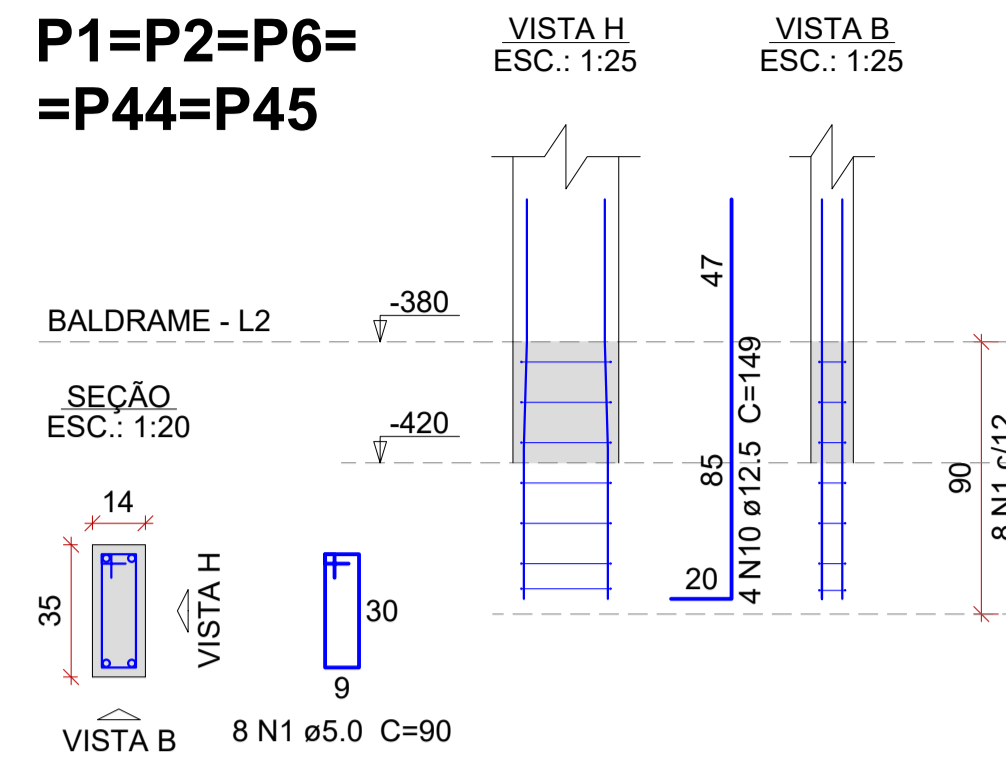

**P3=P5=P18=
=P33=P37**

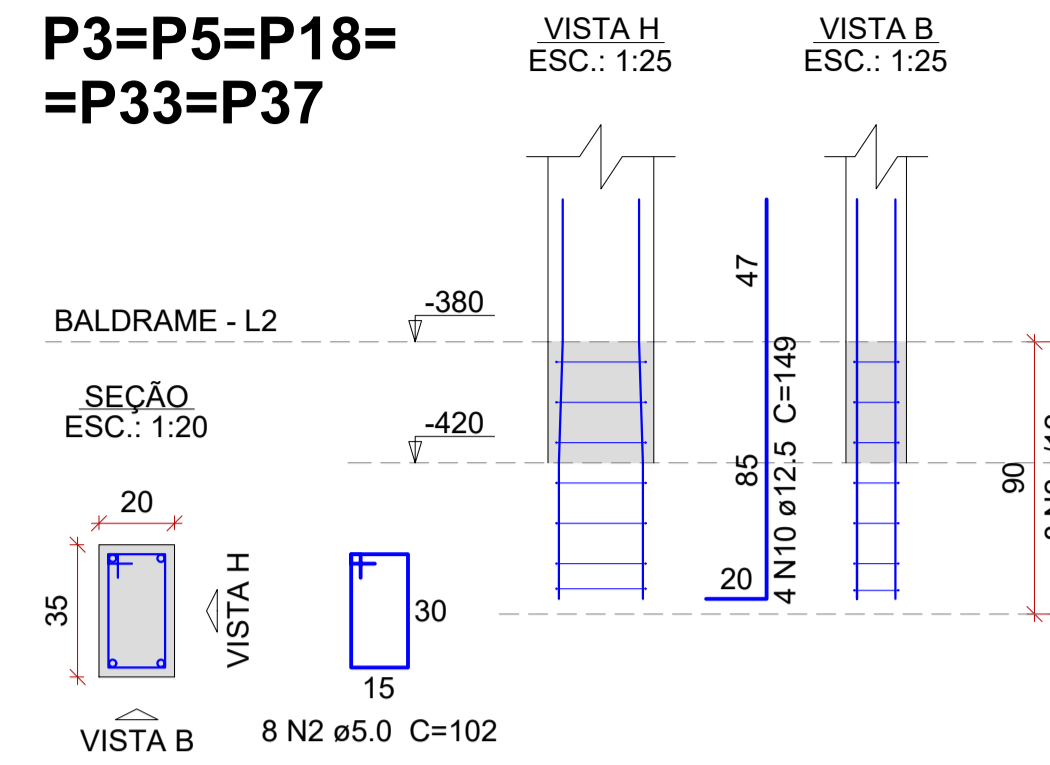

**P11=P25=P34=
=P41**

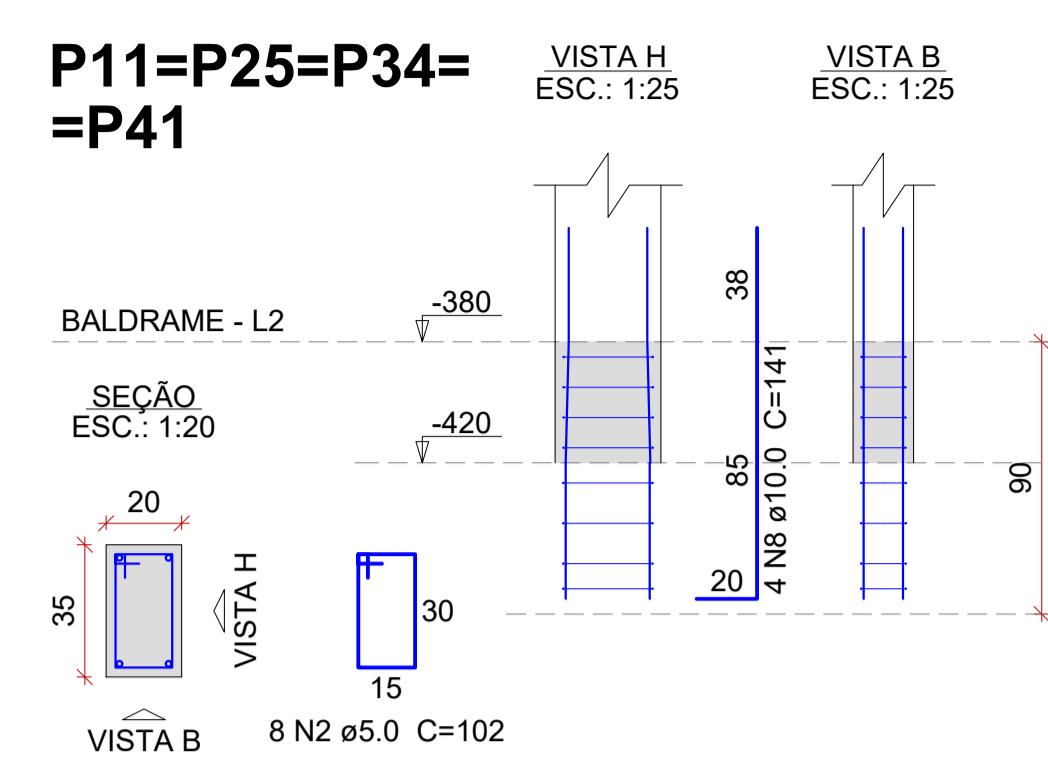

P7

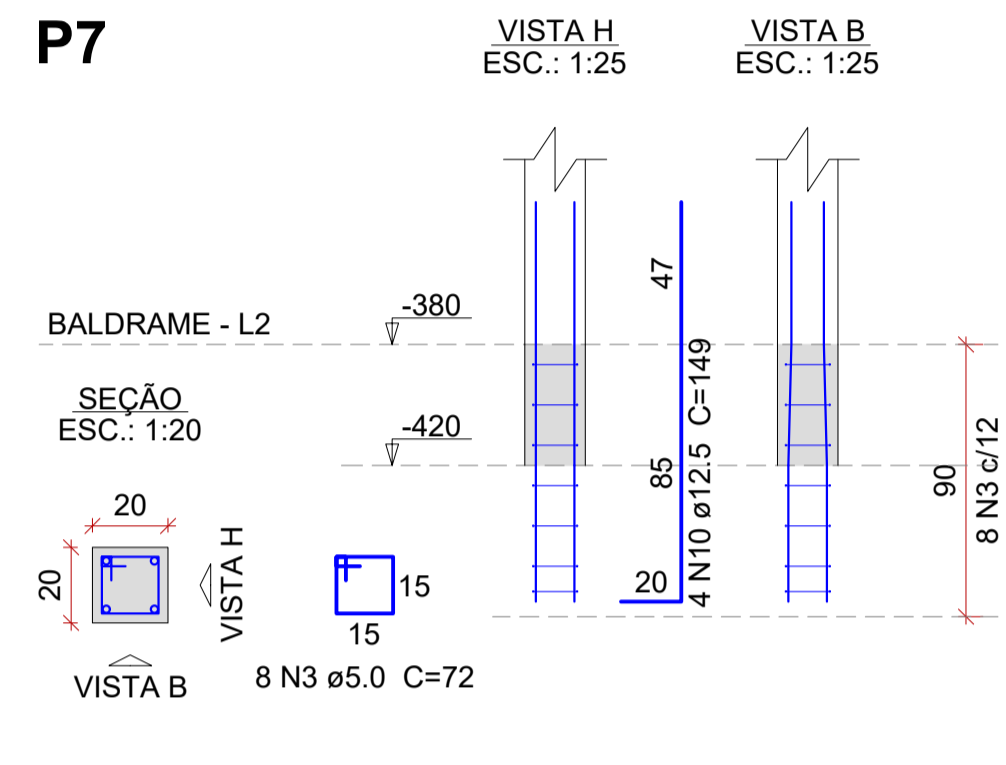

P35

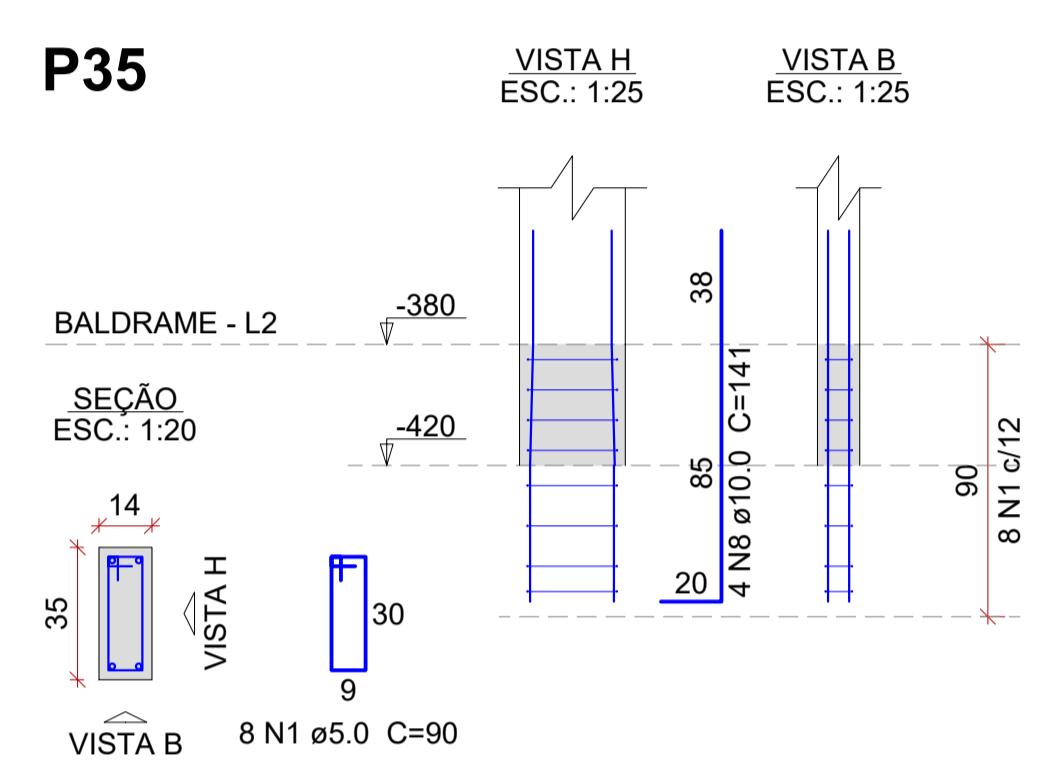

P17=P24=P31

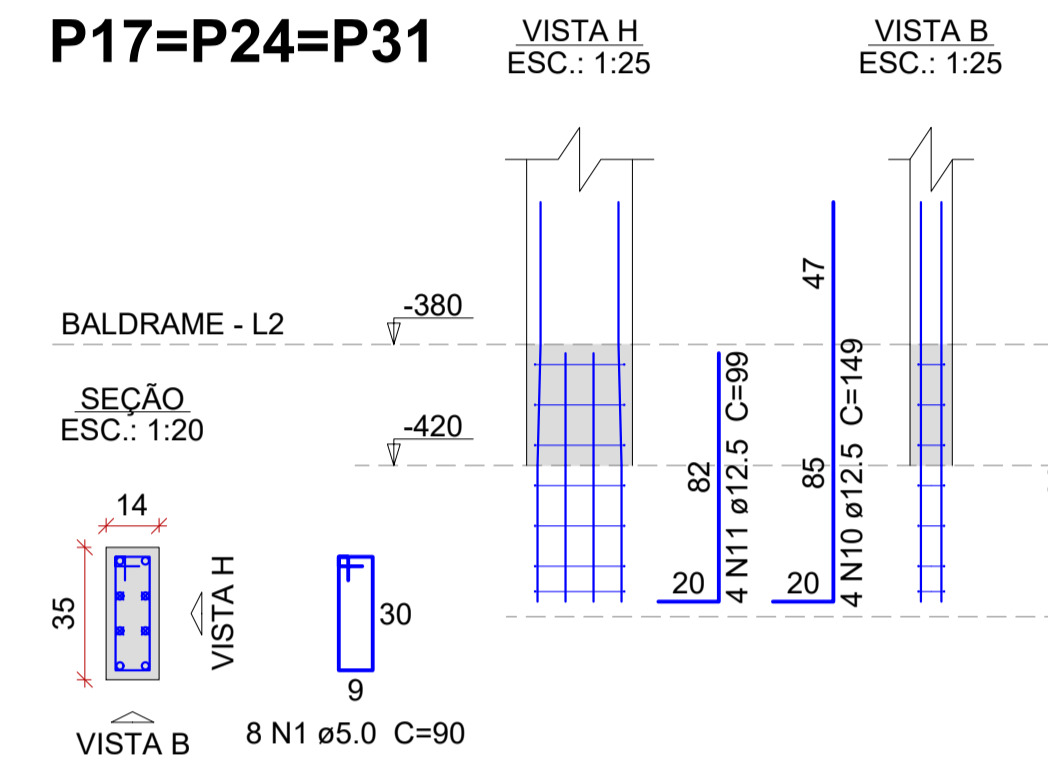

P32

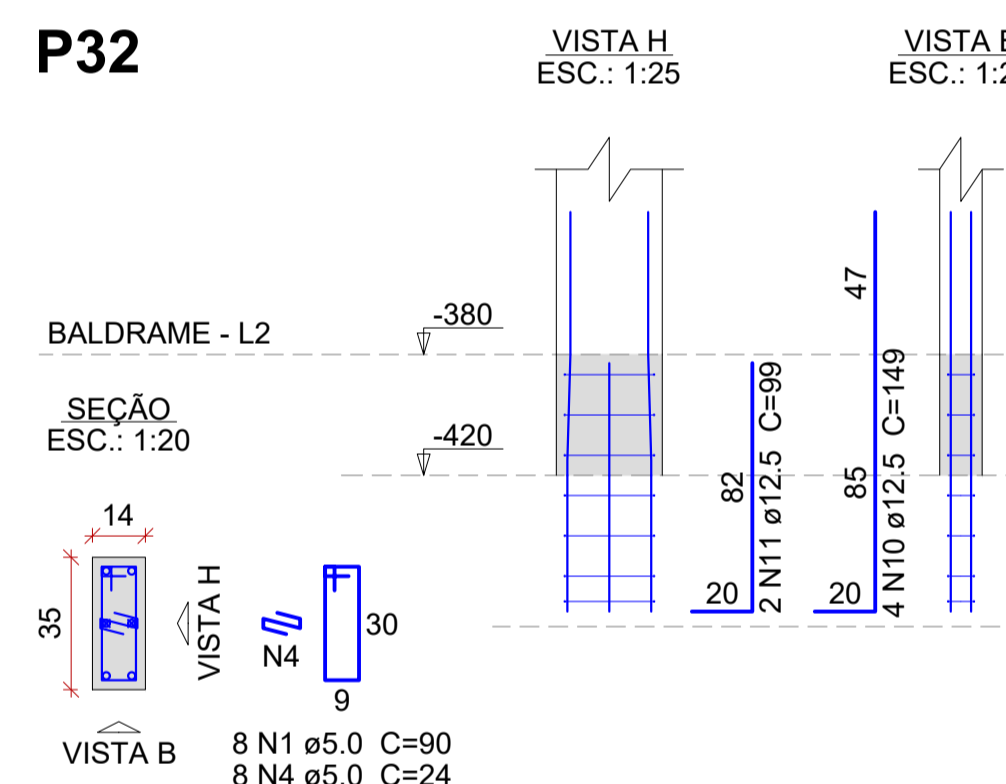

P43=P47=P48

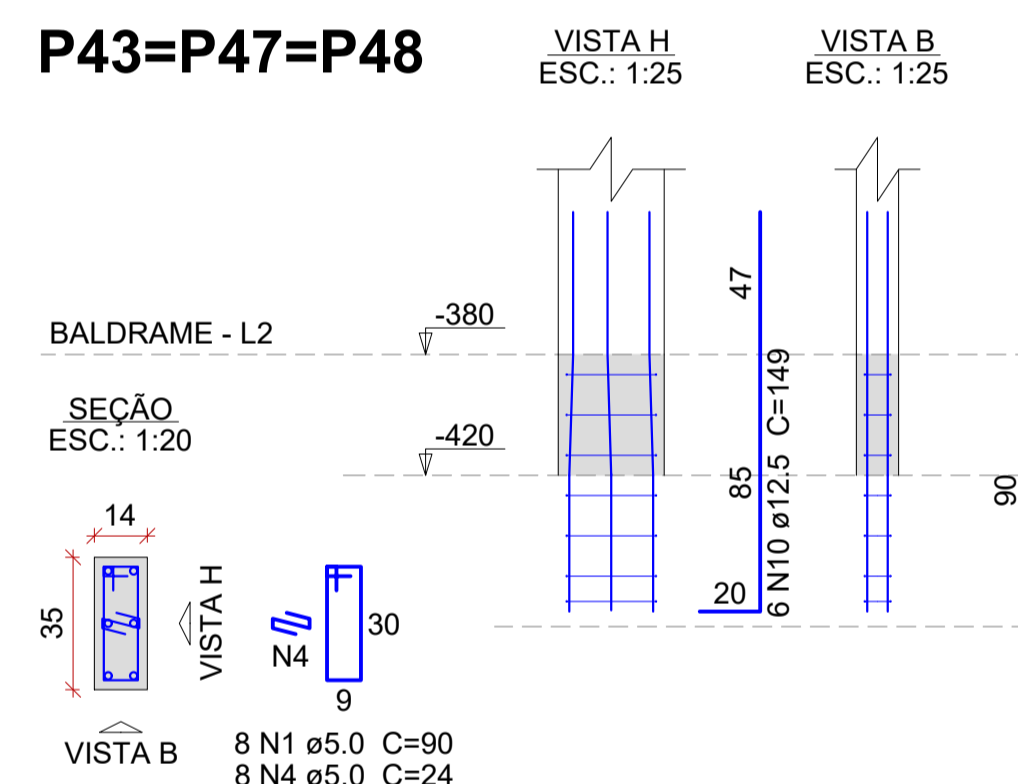

B4=B14=B21=B28=B29

1xC40
PLANTA
ESC.: 1:25

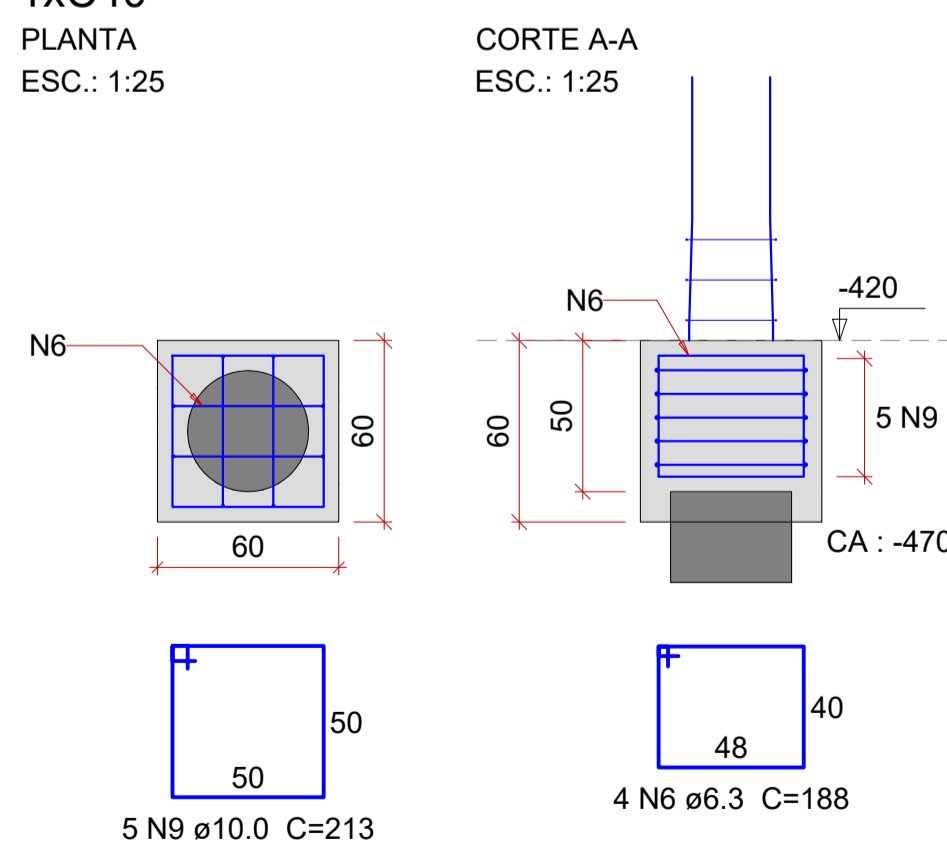

P4=P14=P21

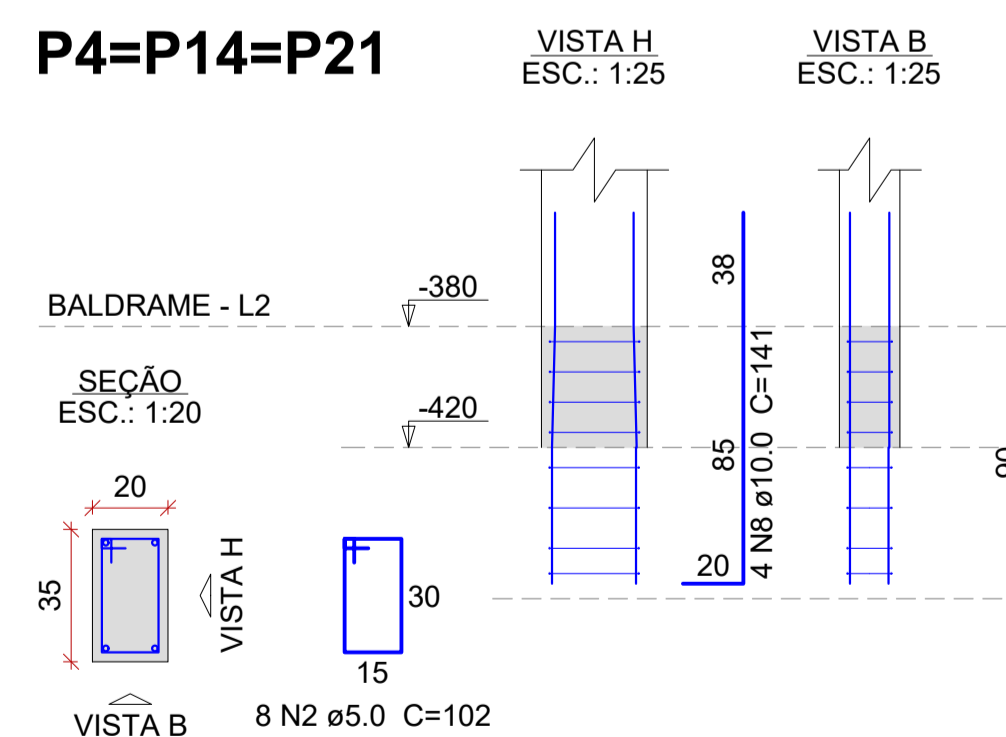

P28=P29=

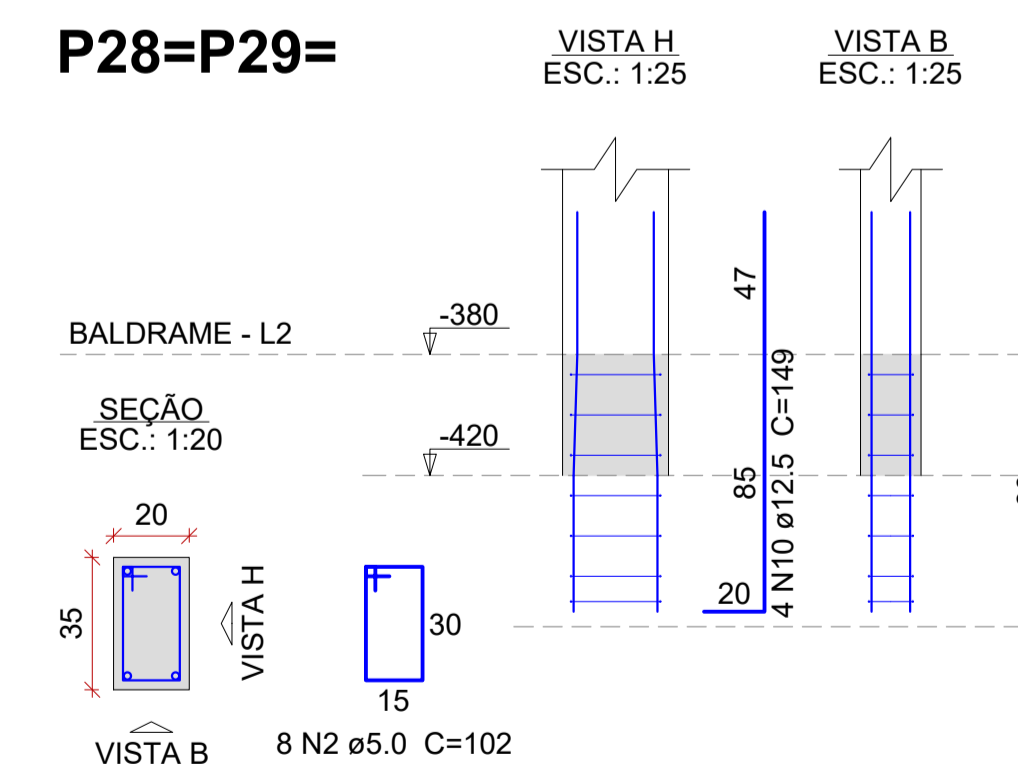

Relação do aço

Baldrame:	5xP1	5xP3
	3xP4	P7
	4xP11	3xP17
	2xP28	P32
Fundação:	P35	3xP43
	23xB1	5xB4

AÇO	N	DIAM (mm)	QUANT	C.UNIT (cm)	C.TOTAL (cm)
CA60	1	5.0	104	90	9360
	2	5.0	112	102	11424
	3	5.0	8	72	576
	4	5.0	32	24	768
CA50	5	6.3	92	168	15456
	6	6.3	20	188	3760
	7	8.0	69	172	11868
	8	10.0	32	141	4512
	9	10.0	25	213	5325
	10	12.5	86	149	12814
	11	12.5	14	99	1386

Resumo do aço

AÇO	DIAM (mm)	C.TOTAL (m)	QUANT (Barras)	PESO (kg)
CA50	6.3	192.2	17	47
	8.0	118.7	10	46.8
	10.0	98.4	9	60.6
	12.5	142	12	136.8
CA60	5.0	221.3	19	34.1
PESO TOTAL (kg)				
CA50		291.3		
CA60		34.1		

Volume de concreto (C-25) = 4.97 m³
Área de forma = 46.38 m²

REVISÃO:	DATA:	DESCRIÇÃO:
R00	03/2022	EMIÇÃO INICIAL



PROPRIETÁRIO / CONTRATANTE: ASSINATURA:

PREFEITURA MUNICIPAL DE WITMARSUM
CNPJ: 83.102.442/0001-76

RESPONSÁVEL TÉCNICO PROJETO: ASSINATURA:

EDUARDO FRANCISCO SILVA DE FIGUEIREDO
ENGENHEIRO CIVIL - CREA: 187051-8-SC

PROJETO: **ESTRUTURAL**

OBRA: CONSTRUÇÃO DE UMA UNIDADE BÁSICA DE SAÚDE DE PORTE 1

LOGRADOURO: RUA 25 DE JULHO BAIRRO: CENTRO Nº: S/N

MUNICÍPIO: WITMARSUM UF: SC CEP: 89157-000

ÁREA TOTAL EDIFICAÇÃO: 346,45m²

CONTEÚDO: BLOCOS DE FUNDAÇÃO E PILARES DE ARRANQUE 1/2

ESCALA: INDICADA DATA: SETEMBRO/2022

CÓDIGO AMAVI: 2744

DESENHISTA: EDUARDO FIGUEIREDO

EST06/24